

NOTE:
 1/16" TOLERANCE
 ALLOWED FROM CENTERLINE
 FOR EMBOSSMENT LOCATIONS
 TOP TO BOTTOM
 AND SIDE TO SIDE.

NOTE:
 THIS LAYOUT BASED ON:
 3'0" X 6'8" EMBOSSED DOOR
 FOR 7'0 DOORS
 EMBOSSMENT LOCATION
 DIFFERENCE IS SPLIT BETWEEN
 TOP AND BOTTOM RAILS

EMBOSSEMENT PROFILE
SECTION A-A

SCALE 16X
 ALL DIMENSIONS TO CENTER OF RADIUS

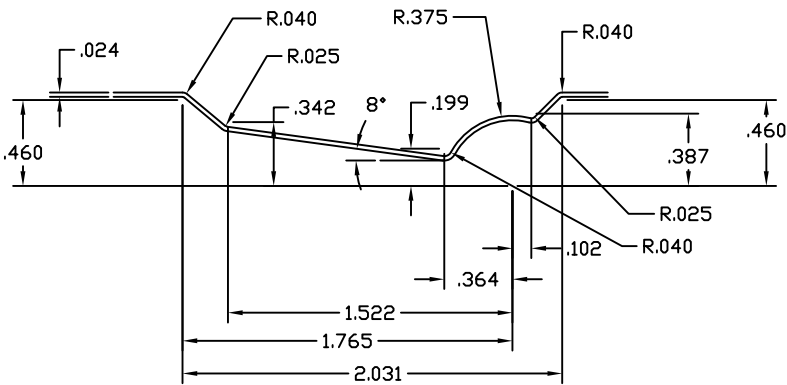

EMBOSSEMENT
SECTION B-B

SCALE 2X
 ALL DIMENSIONS (T.S.C.) TO SHARP CORNER

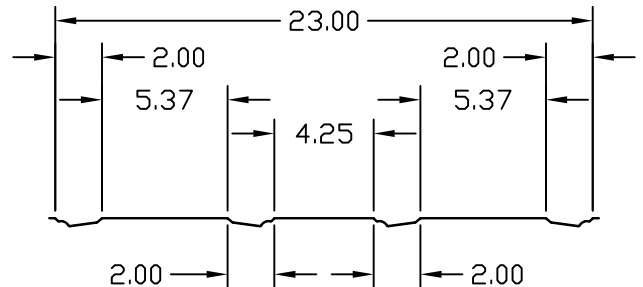

8 PANEL EMBOSSEMENT
 OPTION FOR STEEL DOORS

DWG#	II-15
DATE	1-18-05
NAME	MJP
SECTION	II
PAGE	15