

**MORTISE LOCK PREPARATIONS**

<b>Lock &amp; or Edge Prep Description</b>	<b>Lock Face Bore</b>	<b>Handed</b>	<b>Edge Depth</b>	<b>Process</b>	<b>Prep #</b>	<b>Lock Reinforce- ment</b>	<b>Lock Block: Composite (C) or Wood (W)</b>	<b>DWG Pg #</b>
1-1/4" x 8" EDGE ONLY MORTISE	None	NA	1/8 inch	Bourlag	MT1	45000028	W	II-48
1-1/4" x 8" EDGE ONLY MORTISE	None	NA	1/4 inch	Bourlag	C50	45100050	W	II-48
1 TESA MORTISE	Template	NA	1/4 inch	Bourlag	C51	45100052	W	II-48
1 VINGCARD RH MORTISE	Template	Yes	1/4 inch	Bourlag	C52	45100056	W	II-49
1 VINGCARD LH MORTISE	Template	Yes	1/4 inch	Bourlag	C53	45100056	W	II-49
SAFLOK	Template	NA	1/4 inch	Router	C54		W	II-49
ILCO	Template	NA	1/4 inch	Router	C55		W	II-49

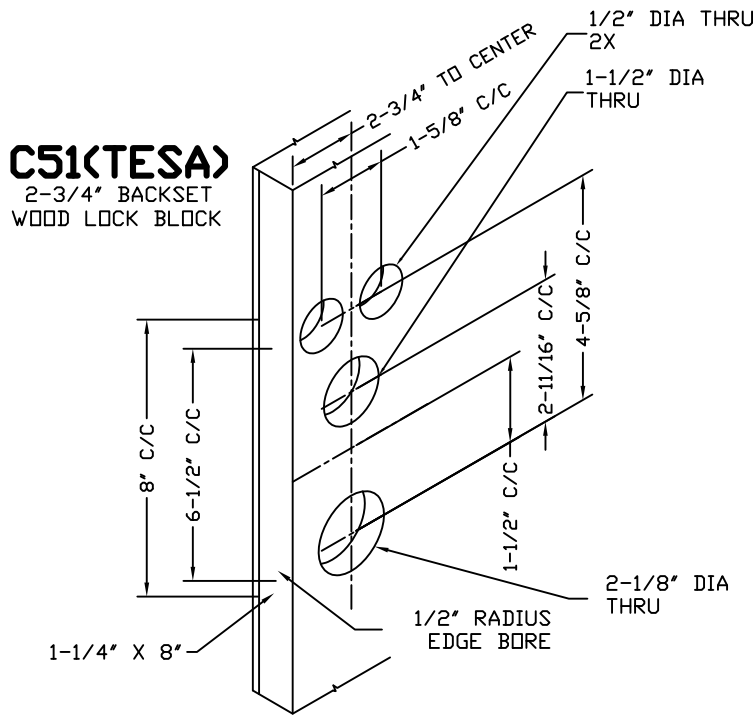
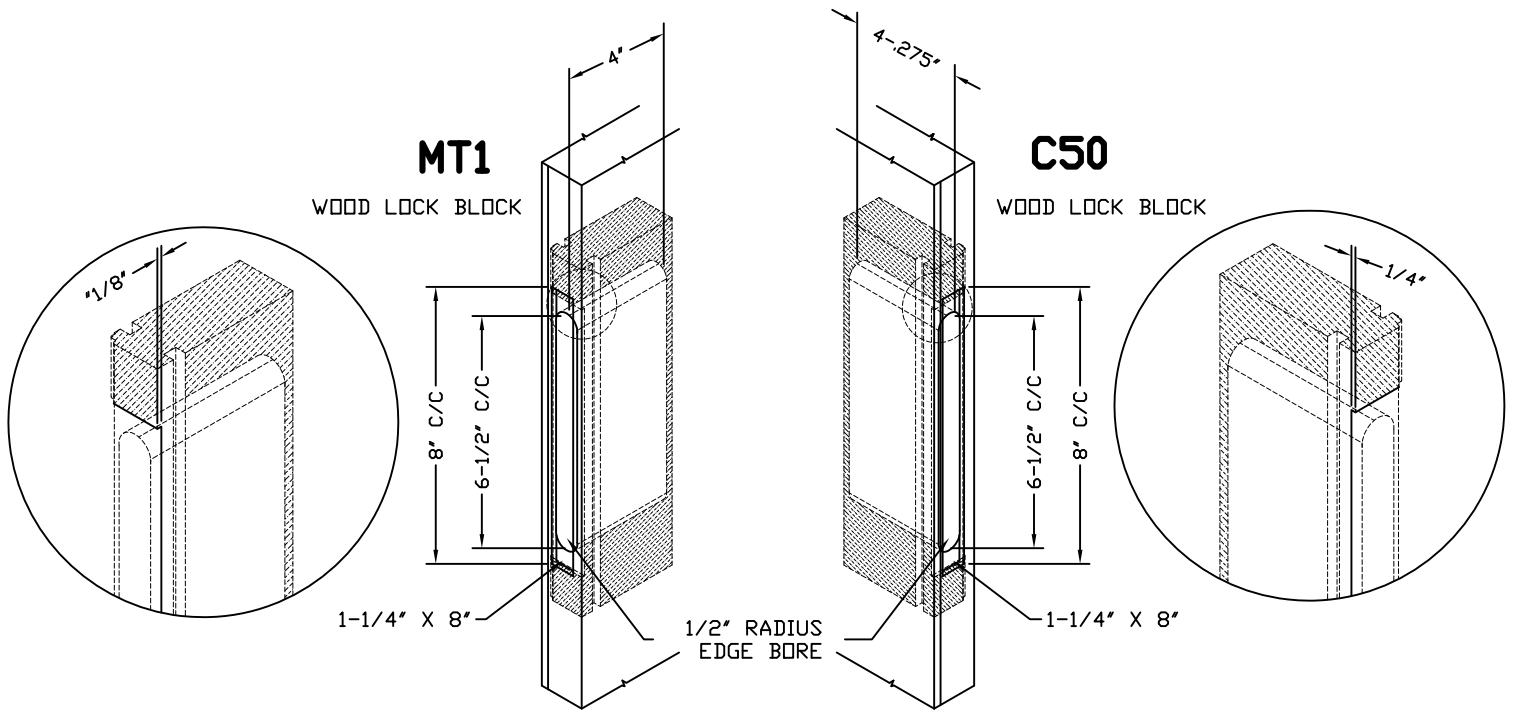

MORTISE EDGE PREP  
FOR STEEL DOORS

DWG#	II-48
DATE	1-20-05
NAME	MJP
SECTION	II
PAGE	48

**C53(VINGCARD)**

LEFT HAND

WOOD LOCK BLOCK

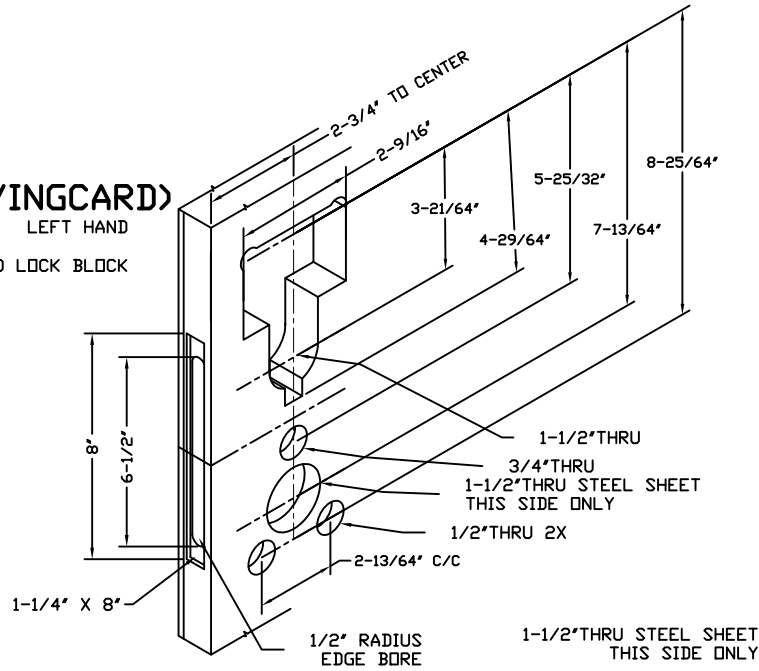

**C52(VINGCARD)**

RIGHT HAND

WOOD LOCK BLOCK

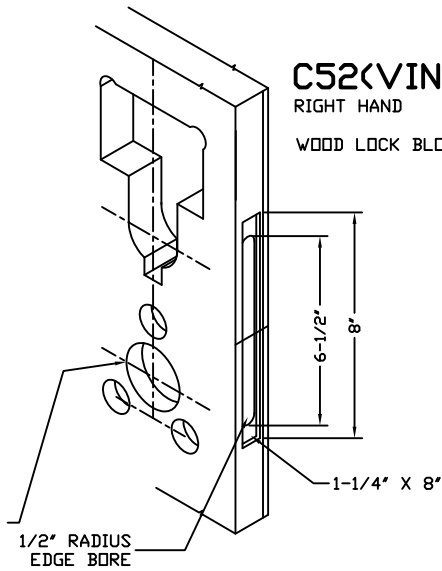

**C54(SAFLOCK)**

WOOD LOCK BLOCK

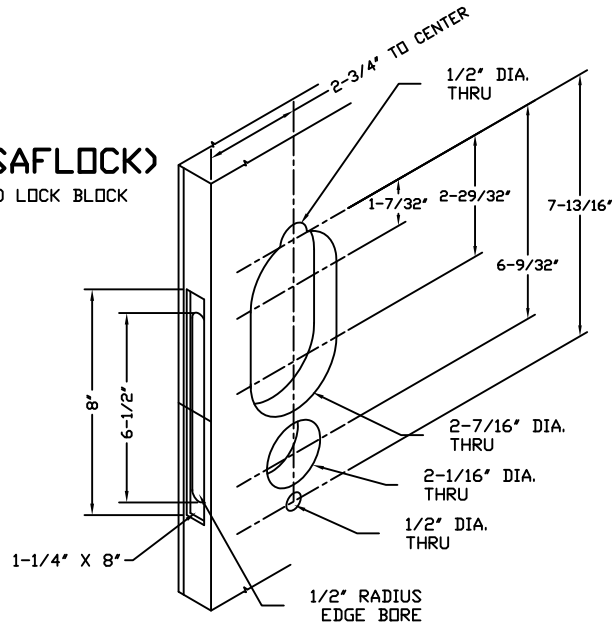

**C55(ILCO)**

WOOD LOCK BLOCK

MORTISE ATTACH  
EDGE PREP  
BY OTHERS  
IN FIELD

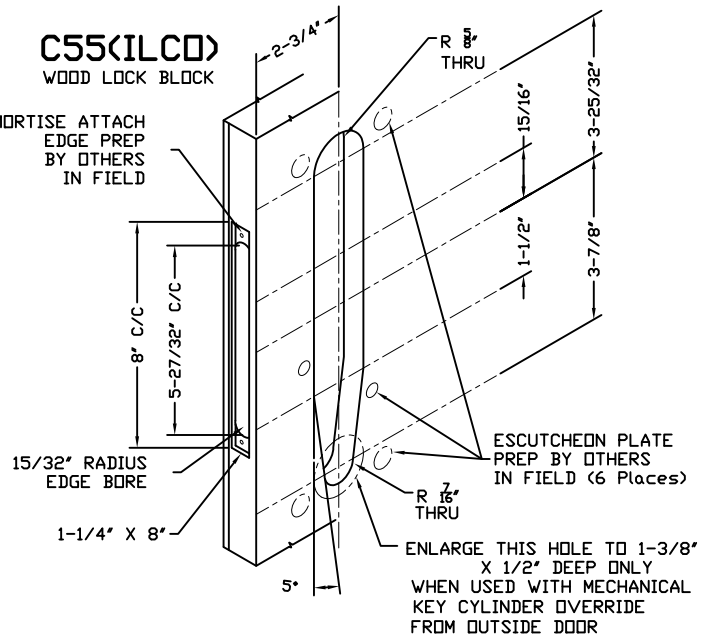

NOTE:  
LOCK MANUFACTURERS TEMPLATE  
REQUIRED TO PROCESS ORDER

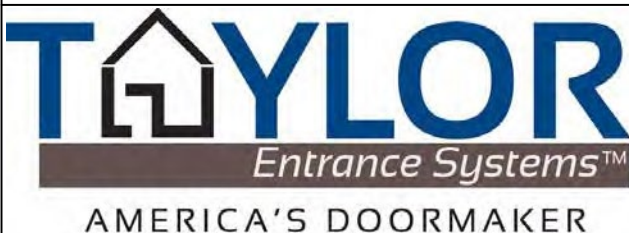

MORTISE EDGE PREP  
FOR STEEL DOORS

DWG#	II-49
DATE	9-26-05
NAME	MJP
SECTION	II
PAGE	49

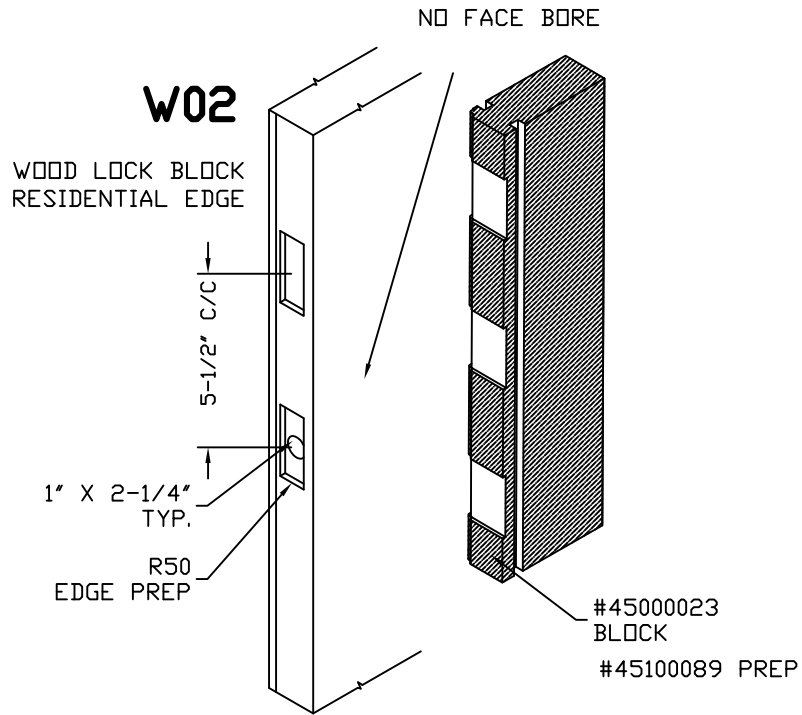
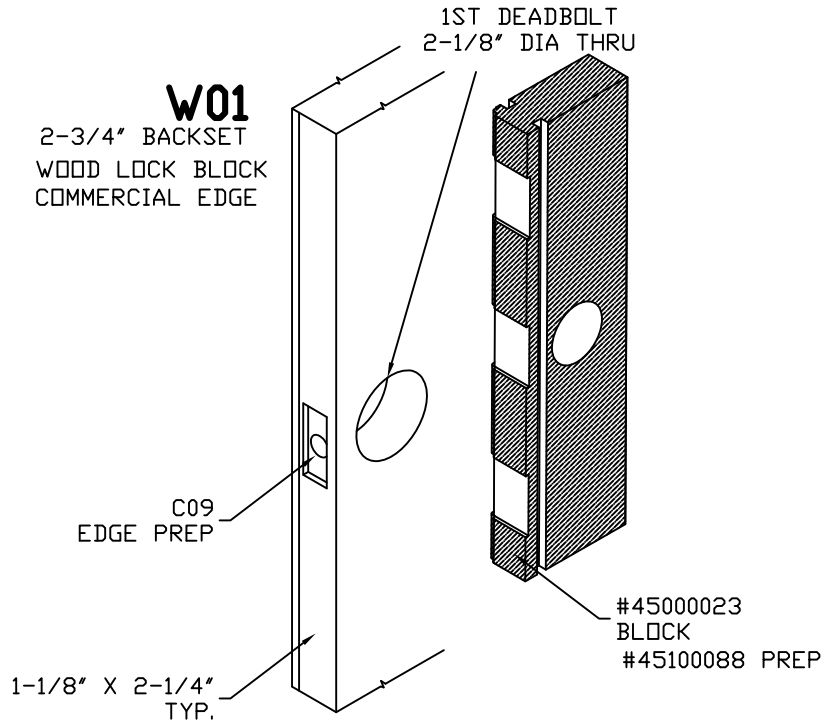

AMERICA'S DOORMAKER

CUSTOM EDGE/BLOCK PREPS  
FOR STEEL DOORS

DWG#	II-49A
DATE	7-17-06
NAME	MJP
SECTION	II
PAGE	49A

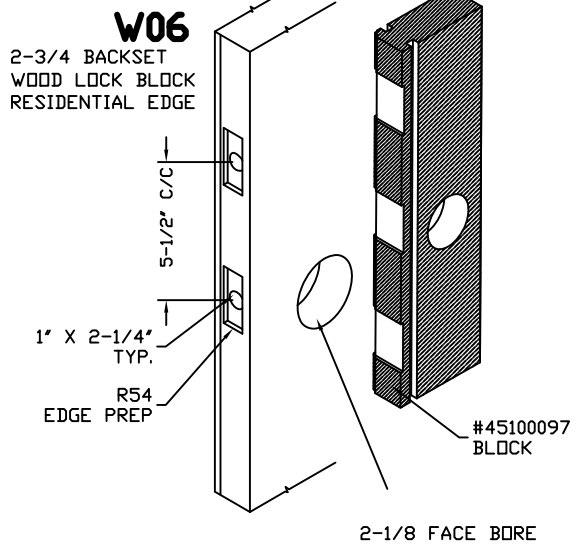
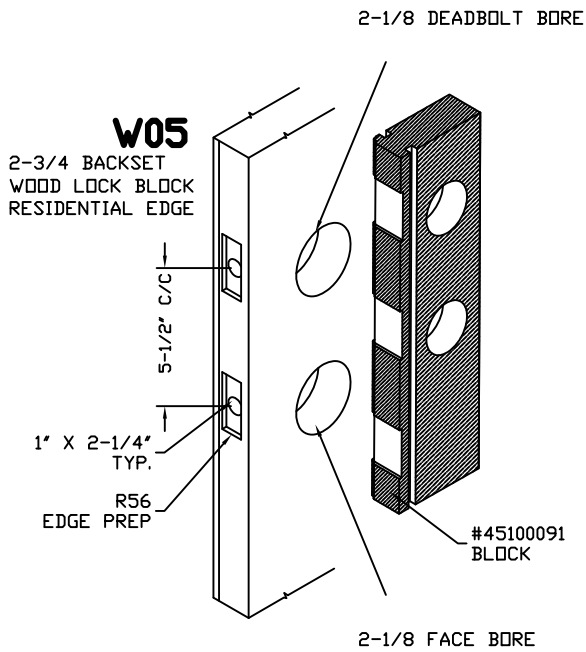
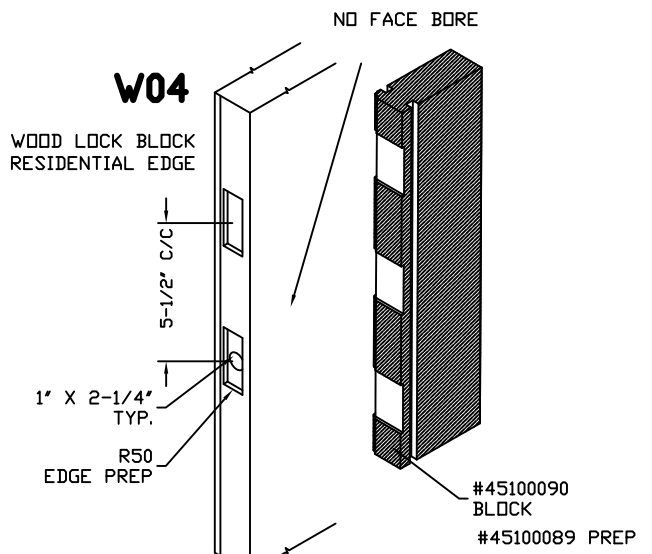
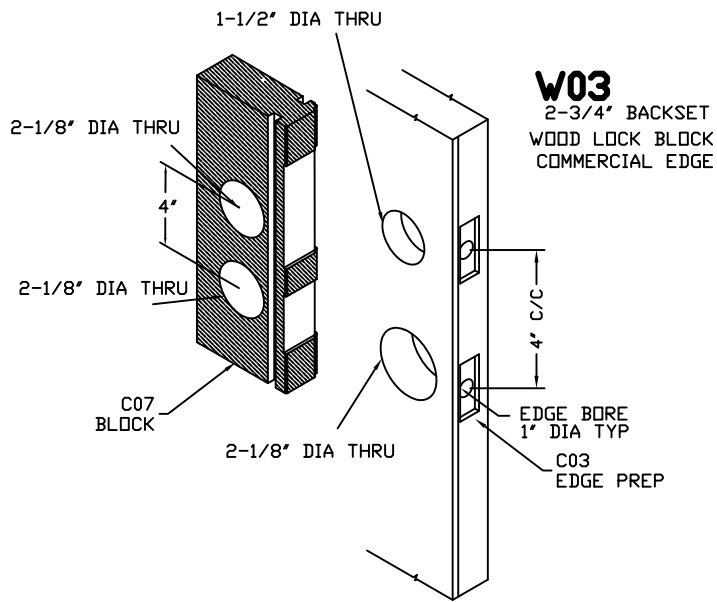

Rev: 3-11-09



CUSTOM EDGE/BLOCK PREPS  
FOR STEEL DOORS

DWG#	II-49B
DATE	3-27-08
NAME	MJP
SECTION	II
PAGE	49B

**C68 VINGCARD SIGNATURE**

LEFT HAND

WOOD LOCK BLOCK

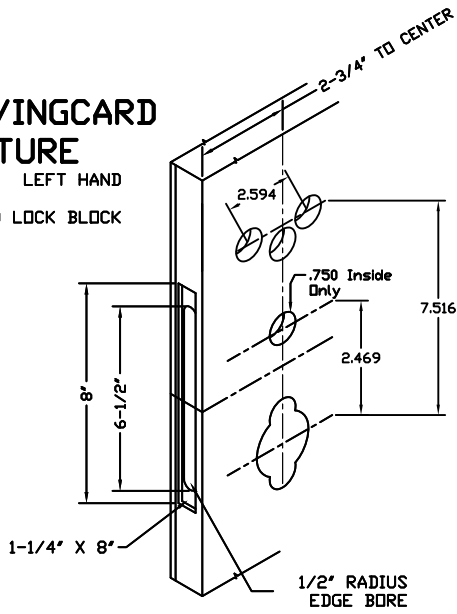

**C69 VINGCARD SIGNATURE**

RIGHT HAND

WOOD LOCK BLOCK

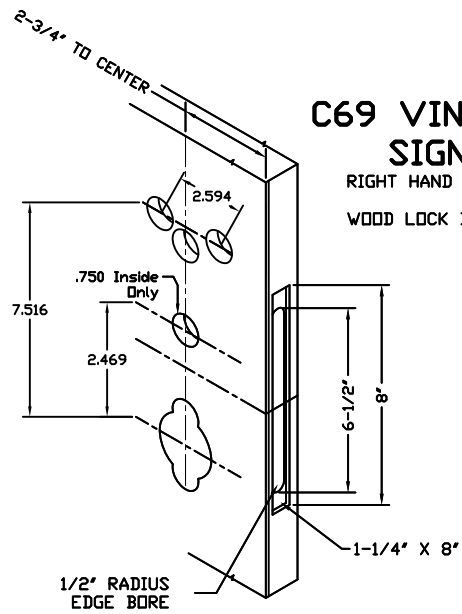

**C70 (ILCO 760)**

WOOD LOCK BLOCK

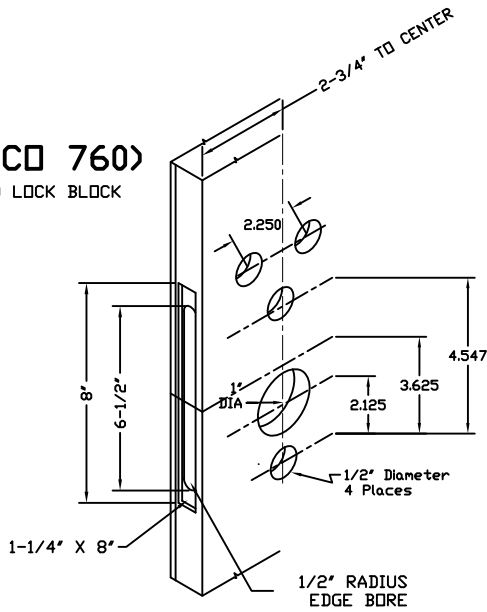

NOTE:  
LOCK MANUFACTURERS TEMPLATE  
REQUIRED TO PROCESS ORDER

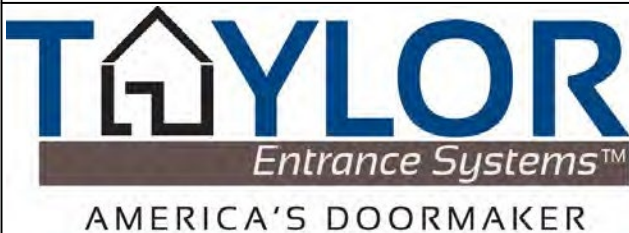

MORTISE EDGE PREP  
FOR STEEL DOORS

DWG#	II-49C
DATE	6-4-19
NAME	KRB
SECTION	II
PAGE	49C